

Owner's Manual

POWERTEC[®]

Bench Top Router Table and Fence

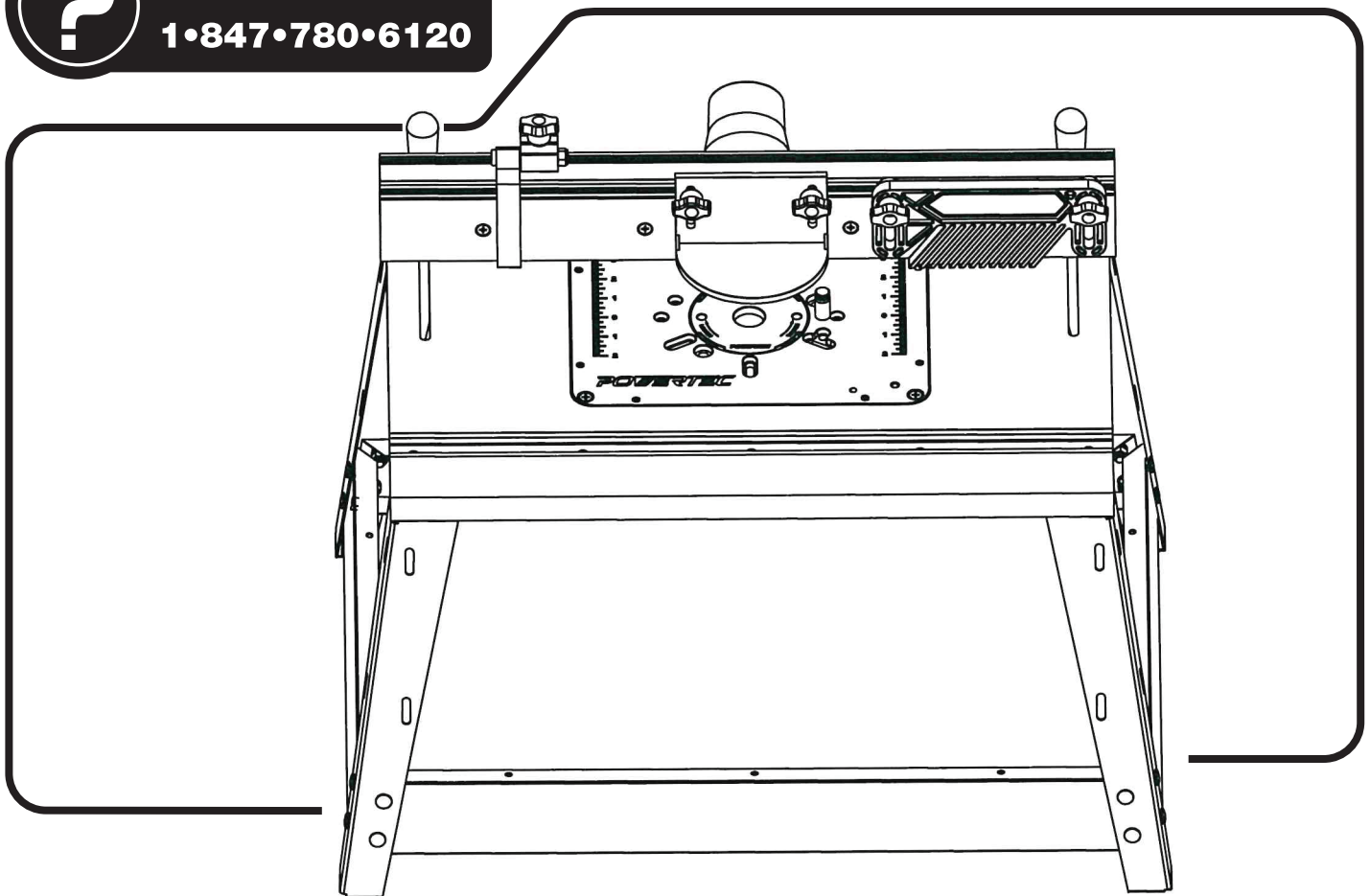

Visit us on the web at www.powertecproducts.com



You will need this manual for safety instructions, operating procedures, and warranty. Put it and the original sales invoice in a safe, dry place for future reference.

TABLE OF CONTENTS

SECTION PAGE



SAFETY RULES / WARNINGS 1-3

General Tool Safety
Tool Specific Warnings



PARTS AND CONTENTS 4

Assembly Parts



ASSEMBLY 5-8

Table Assembly
Fence Assembly



OPERATION 9-10

General Routing



MAINTENANCE 10

General Maintenance



WARRANTY 11

PRODUCT SPECIFICATIONS

RECOMMENDED ROUTER BIT SPEEDS

BIT DIAMETER	MAXIMUM SPEED
Up to 1" (25 mm)	22,000 -24,000 rpm
1" to 2" (25 mm–51 mm)	18,000-22,000 rpm
2" to 2-1/2" (51 mm–64 mm)	12,000-16,000 rpm
2-1/2" to 3-1/2" (64 mm–89 mm)	8,000-12,000 rpm

NOTE: Always follow bit manufacturer's speed recommendations. Some bit designs require specific speeds for safety or performance.

**WARNING**

For your own safety, read all of the rules and precautions before operating tool.

WARNING

Always follow proper operating procedures as defined in this manual even if you are familiar with use of this bench top router table or any tool used with this bench top router table. Remember that being careless for even a fraction of a second can result in severe personal injury.

Before using another tool with this product, always read, understand and follow the instructions and safety warnings in the owner's manual for that tool. If you do not have the owner's manual, obtain one from the tool's manufacturer before using it with this product.

You must be familiar with the use of any tool or accessory used with this bench top router table. The supplier cannot be held responsible for any accident, injury or damage incurred while using this bench top router table with any tool.

It is the responsibility of the purchaser of this product to ensure that any person using this product reads and complies with all instructions and safety precautions outlined in this manual prior to use.

WARNING

Some dust created by operation of power tools can expose you to chemicals known to the State of California to cause cancer, birth defects or other reproductive harm. To reduce your exposure to these chemicals, work in a well ventilated area and work with approved safety equipment. Always wear OSHA/NIOSH approved, properly fitting face mask or respirator when using such tools.

CAUTION

Do not modify or use this bench top router table for any application other than that for which it was designed.

FOLLOW ALL STANDARD SHOP SAFETY PRECAUTIONS, INCLUDING:

- Keep children and visitors at a safe distance from work area.
- Keep work area clean. Cluttered work areas invite accidents. Work area should be properly lit.
- Do not use power tools in dangerous environments. Do not use power tools in damp or wet locations. Do not expose power tools to rain.
- Wear proper apparel. Do not wear loose clothing, gloves, neckties, rings, bracelets or other jewelry which may get caught in moving parts of the tool.
- Wear protective hair covering to contain long hair.
- Wear safety shoes with non-slip soles.
- Wear safety glasses complying with United States ANSI Z87.1. Everyday glasses have only impact resistant lenses. They are NOT safety glasses.
- Wear face mask or dust mask if operation is dusty.
- Be alert and think clearly. Never operate power tools when tired, intoxicated or when taking medications that cause drowsiness.
- A guard or any other part that is damaged should be properly repaired or replaced. Do not perform makeshift repairs.
- Use the right tool for your job. Do not force your tool to do a job for which it was not designed.
- Use safety equipment such as featherboards, push sticks and push blocks, etc., when appropriate.
- Maintain proper footing at all times and do not overreach.
- Do not use the router table as a step or seat.

WARNING

- To avoid serious injury, turn off and unplug the router before attaching the router base, changing accessories or adjusting the cutter height/fence position.
- Assemble the featherboard(s) at least 1" (2.5 cm) from the router bit to prevent kickback.
- Do not use the featherboard as a push block.

CAUTION

Think safety! Safety is a combination of operator common sense and alertness at all times when tool is being used.

WARNING

Do not use the bench top router table until it is completely assembled and you have read and understood this entire operating manual and the operating manual of the tool being used with this bench top router table.

**SAVE ALL WARNINGS AND INSTRUCTIONS
FOR FUTURE REFERENCE**

2



SPECIFIC SAFETY WARNINGS

⚠ DANGER

- To avoid serious injury, keep hands and fingers away from the spinning router bit. Be aware of the bit at all times.

⚠ WARNING

AVOID THIS SITUATION!

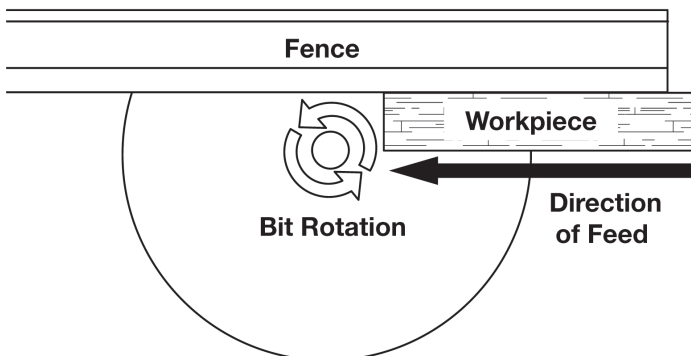

- NEVER FEED YOUR WORKPIECE BETWEEN THE BIT AND THE FENCE. Because of the direction of the bit's rotation, the bit could "grab" the workpiece and propel it away from the table at a high velocity, potentially resulting in property damage and serious injury to anyone in its path.
- When the bit grabs the workpiece, your hands could be drawn into the bit, resulting in serious injury

⚠ CAUTION

- Read, understand, and follow your router manufacturer's safety warnings and instructions.
- Turn off and unplug your router before installing or adjusting the bit or adjusting the bench top router table and accessories. Never adjust the fence, plate, reducing rings, or any part of the router or router table while the router is running.
- Place the router table on a flat surface to prevent tipping or sliding. Never stand on the router table.
- Set the bit guard directly over the router bit, at least 1/2" above the top of the bit or the top of the workpiece (whichever is highest), make sure the bit doesn't cut into the bit guard.
- When adjusting the position of the fence, make sure no part of the aluminum fence will contact the router bit.
- Do not attempt to rout warped, twisted, or bowed workpieces. All workpieces must have flat faces and square edges.
- Do not attempt to rout very large workpieces on a router table. Very large workpieces can be difficult to control and can cause the router table to tip over.
- Only use router bits in your router. Never use tools such as carving burrs, mounted abrasives, wire wheels, or drill bits, even if the shanks match the diameter of the router collet.
- Wear gloves when handling router bits. Cutting edges are sharp.

- Never use dirty, dull, or damaged router bits. Remove wood-resin build-up with a cleaner specifically formulated for cutting tools. Have dull bits sharpened by a qualified person. Discard damaged bits.
- Make sure at least 75% of the router-bit shank length is securely held in the router collet. To ensure a secure hold, leave 1/16" to 1/8" (2 mm-3 mm) between the end of the bit shanks and the bottom of the collet.
- Use the insert-plate reducing ring with the smallest opening that allows the bit to pass through it. A large gap around the bit can allow the workpiece to tip into the bit and kick back.
- Position the fence faces as close as possible to the bit. Turn the bit by hand to check for interference. Firmly tighten the fence face knobs before routing.
- Adjust router speed to match the diameter of the bit. Reduce router speed when using large-diameter bits. See *Recommended Router Bit Speeds* for recommended router speeds.
- Make sure the router motor is securely clamped in the base before starting the router.
- Always support the workpiece with the fence or start pin. Only use the starter pin with router bits that have a guide bearing. Failure to use these guides diminishes your ability to control the workpiece and greatly increases the chance of damage to the workpiece and/or serious personal injury.
- When using the fence, always position the bit guard over the router bit and as close to the workpiece surface as possible.
- Never remove a large quantity of stock in one cut. Make several progressively deeper cuts, adjusting the router bit or fence position between cuts.
- Keep hands away from the rotating bit and your body out of the path of the cut. Always use the bit guard, Use push sticks, push blocks, and feather boards whenever possible, especially when routing narrow workpieces. Turn off the router before clearing parts of scrap.
- Avoid awkward hand positions, where a sudden slip could cause contact with the rotating bit. Never overreach.
- Avoid routing small parts. Rout the profile on a large workpiece and then cut the part to final size from the large workpiece. If you must rout a small part, build an appropriate jig or hold the part with a wood handscrew clamp.
- Make sure the workpiece is clear of the bit and the bit comes to a complete stop before adjusting the workpiece position. Never start the router with the workpiece in contact with the bit.
- Avoid kickbacks. Kickbacks occur when the workpiece binds or lifts off the table while being routed, causing it to be thrown back toward the operator. To avoid kickbacks and potential injury, use sharp bits, keep the machine aligned and maintained properly, and adequately support the workpiece. Do not attempt to rout workpieces that are twisted, warped, or bowed, or that have loose knots.



- **NEVER trap a workpiece between the bit and the fence.** When forming a profile on the straight edge of a workpiece, always rout with the bit housed in the fence and the edge of the workpiece against the fence.
- **Whenever routing a profile in which material is not being removed below a protruding portion of the bit, or a part of the profile is trapped between cutters above and below, take extra precautions to prevent the workpiece from lifting off the table surface during routing.** A workpiece lifting off the table can kick back and cause serious personal injury. When routing these profiles, it is especially important to use straight, flat stock and avoid warped, bowed, or twisted stock.
- **Always feed the workpiece against the rotation of the bit.** A table-mounted router spins the bit counterclockwise, so feed the workpiece from right to left as you face the table. This provides better control because the rotation of the bit is backward and toward the fence instead of forward and away from it.
- BEFORE plugging in and turning on the router, always make sure the MDF adjustable fence faces are fully secured and the bit can rotate freely without touching the fence faces. An exception to this is if the infeed fence face is set to provide zero-clearance support for the workpiece, as described in the *Adjusting the Fence Faces*.
- **Periodically check the tightness of fasteners and adjustment and locking knobs and the alignment of the fence.** Loose fasteners and knobs and a misaligned fence can cause personal injury.
- **This router table is designed for a specific application.** Do not modify and or use it for any other application. If you have questions relative to the application of the router table, DO NOT use it until you have contacted POWERTEC and have been advised accordingly.

Guidelines for using extension cords

Extension cords are only to be used for temporary purposes. They do not replace the need for installation of outlets and proper wiring where necessary.

Make sure your extension cord is in good condition. When using an extension cord, be sure to use one heavy enough to carry the current your product will draw. An undersized cord will cause a drop in line voltage resulting in loss of power and overheating. The table below shows the correct size to be used according to cord length and nameplate ampere rating. When in doubt, use a heavier cord. The smaller the gauge number, the heavier the cord.

AMPERAGE @120	EXTENSION CORD LENGTH					
	25'	50'	75'	100'	150'	200'
RECOMMENDED WIRE GAUGE						
0-5	16	16	16	14	12	12
5.1-8	16	16	14	12	10	NR
8.1-12	14	14	12	10	NR	NR
12.1-16	12	12	NR	NR	NR	NR
NR=Not Recommended						

- Extension cords with an equipment grounding conductor must be used at all times.
- Make sure your extension cord is properly wired and in good condition. Always replace a damaged extension cord or have it repaired by a qualified person before using it.
- Protect your extension cords from sharp objects, excessive heat and damp/wet areas.
- Extension cords must be a minimum of 16 AWG and be rated for the equipment in use.
- Use a separate electrical circuit for your tools. This circuit must not be less than a #12 wire and should be protected with a 15 A time-delayed fuse. Before connecting the motor to the power line, make sure the switch is in the OFF position and the electric current is rated the same as the current stamped on the motor nameplate. Running at a lower voltage will damage the motor.

ASSEMBLY PARTS AND CONTENTS

UNPACKING: Check for shipping damage. Check immediately whether all parts and accessories are included.

Table Assembly

Refer to Figure 1

Shows the contents off the table assembly

ITEM	DESCRIPTION	QTY
AA	Legs	4
BB	Long Tie Bars (26" long x 2-3/4" wide with two 3/4" flanges)	2
CC	Short Tie Bars (18" long x 2-3/4" wide with two 3/4" flanges)	2
DD	Carriage Bolts 5/16"-18 x 3/4"	16
EE	Nuts 5/16"-18	16
FF	Lock Washers 5/16"	16
GG	Table Top (15-3/4" wide x 23-5/8" long x 1" thick)	1
HH	Hexagon set screw 1/2"-20*19.5LX (3/8"-24 internal thread)	4
II	Hex nut 1/2"-20	4
JJ	Adjustment screw 3/8"-24 (1/4"-20 internal thread)	4
KK	Hex nut 3/8"-24	4
LL	Flat head locking screw (1/4"-20)	4
MM	Main Aluminum Insert	1
NN	Reducing Rings (Include solid insert, 1", 1-7/8" & 2-5/8" opening)	4
OO	Ring Wrench	1
PP	M5 Starting pin with M6 Insert	1
QQ	Screw 3/16" x 5/8" L	8
RR	Leveling Screw 1/4"-20 x 5/8" L	8
SS	Hex Wrench	1

Figure 1

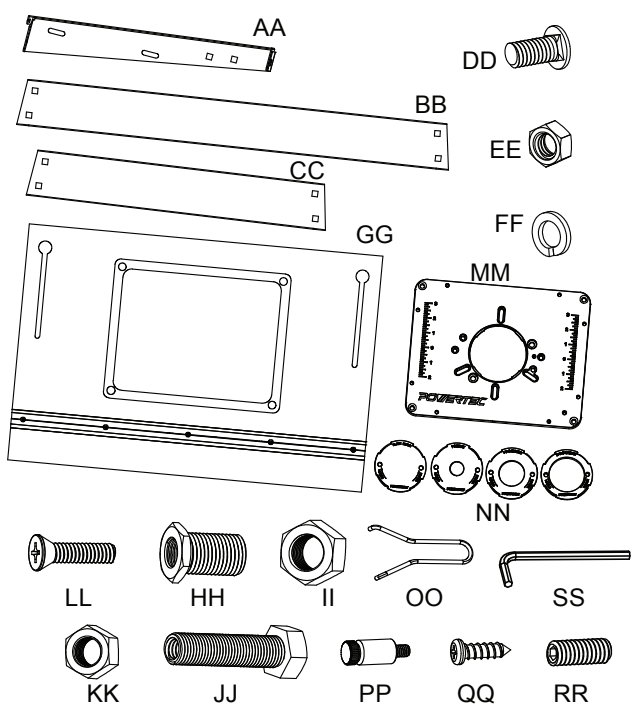

Fence Assembly

Refer to Figure 2

Shows the contents off the fence assembly

ITEM	DESCRIPTION	QTY
A	Fence	1
B	Fence lock knobs 5/16"-18	2
C	Washers 5/16"	2
D	T-Bolt 5/16"-18 x 1-1/2"	4
E	MDF adjustable fence faces	2
F	Flat head screws 1/4"-20 x 1-1/2"	4
G	Wing Knobs, 1/4"-20	6
H	Bit guard	1
I	T-Bolts 1/4"-20 x 1"	2
J	Nylon Washer 1/4"	2
K	Router dust port	1
L	Pan head screws M4 x 10 mm	2
M	Washers 1/4"	2
N	Featherboard	1
O	Nylon Spacers	2
P	Tape measure with adhesive backing (right to left)	1
Q	3" Flip stop	1
R	4 mm Round Rods	2
S	1/4" Square Rods	2
T	Wing Knobs, 5/16"-18	2

Figure 2

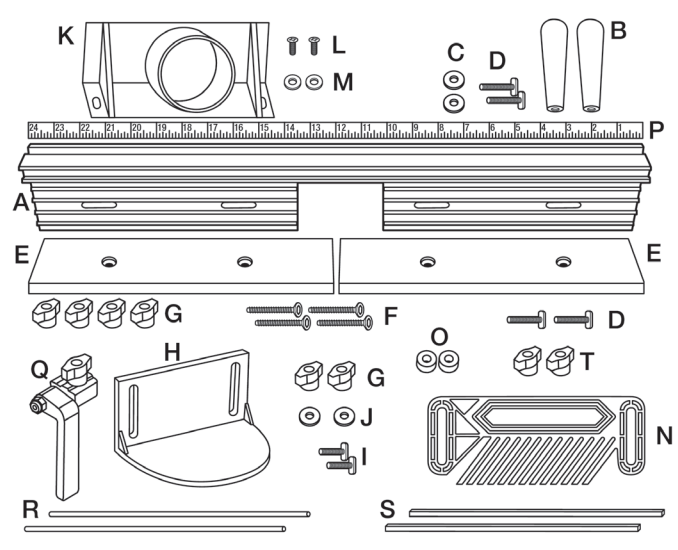

ASSEMBLE BENCH TOP ROUTER TABLE

Model No.		71963
Top (with wood top)	A	23-5/8" x 15-3/4" (600x400mm)
Leg Spacing	B	27-1/8" x 19-1/4" (689x489mm)
Height (with wood top)	C	15-1/2" (394mm)
Shelf		23-5/8" x 15-3/4" (600x400mm)
Shelf Height		14-1/2" (369mm)

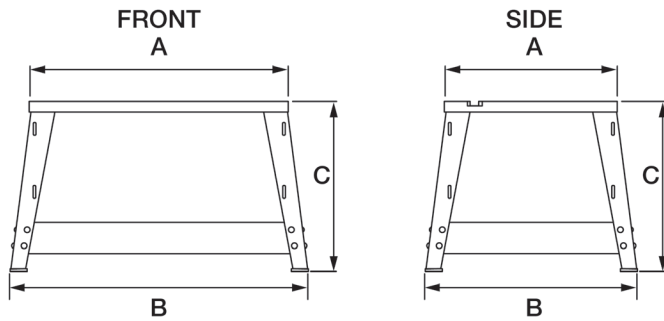

WARNING

Refer to Figure 3-8

Do not use the bench top router table until it is completely assembled and you have read and understood this entire operating manual and the operating manual of the tool being used with this bench top router table.

Figure 3

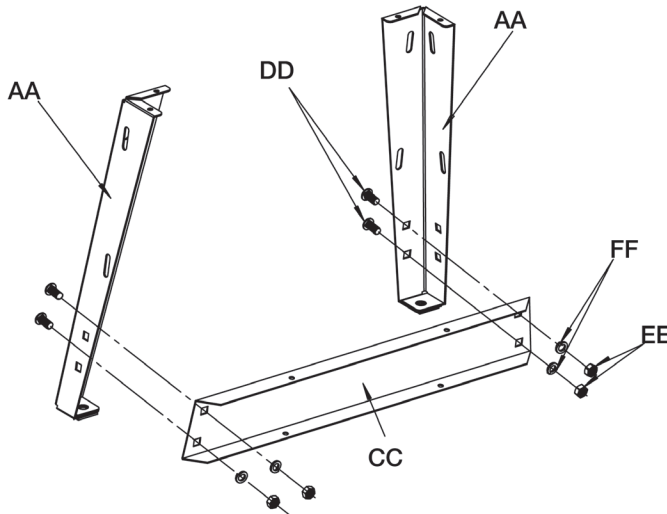

1. Attach short tie bar (CC) to each pair of legs (AA) using carriage bolts 5/16"-18 x 3/4" (DD), lock washers 5/16" (FF) and nuts 5/16"-18 (EE). Finger tighten the nuts.

Figure 4

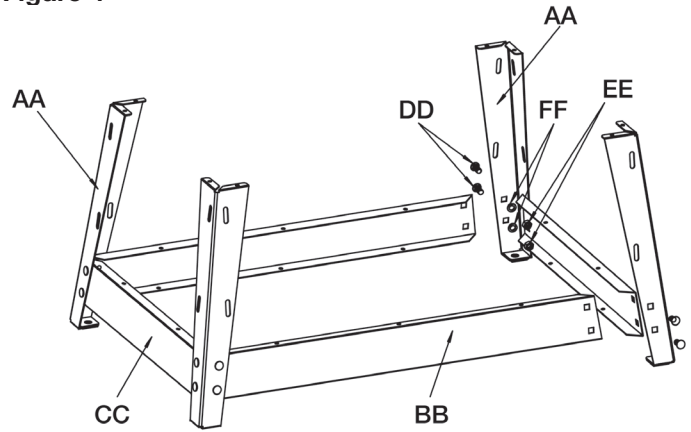

2. Attach short rail/leg assembly to each long rail (BB) using four carriage bolts 5/16"-18 x 3/4" (DD), lock washers 5/16" (FF) and nuts 5/16"-18 (EE). Finger tighten the nuts.

Figure 5

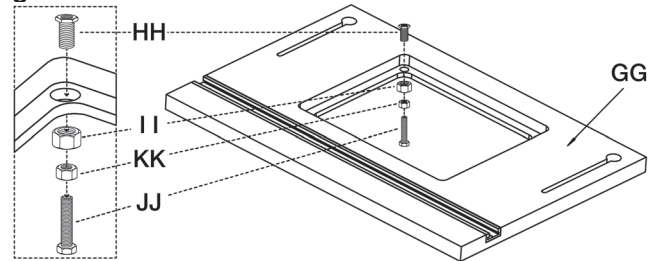

3. Place Hexagon Set Screws (HH) into the recessed hole openings. Hand-tighten Hex Nut (II) onto the bottom of each Hex Set Screw (HH) then tighten against the bottom of the table. Install Hex Nut (KK) onto Adjustment Screw (JJ) then thread it into Hexagon Set Screw (HH). DO NOT tighten at this time. Repeat for all four holes.

Figure 6

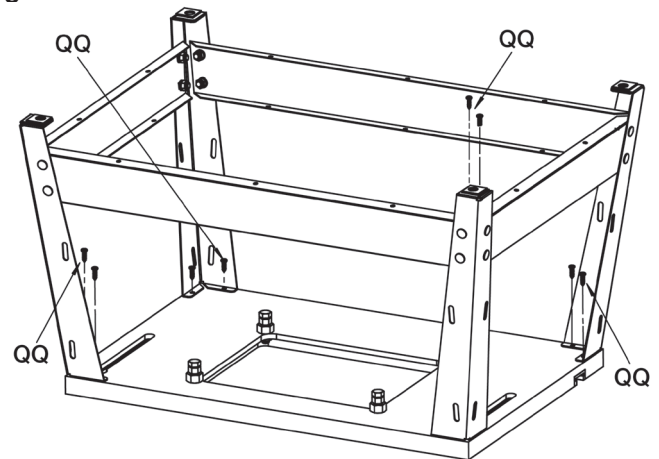

4. Place leg assembly upside down (Figure 6) then position onto bottom of assembled table top. Align holes in top of each leg with pre-drilled pilot holes in the table. Fasten the Leg assembly to the top with eight 3/16" coarse-thread screws (QQ) Use handheld screw driver to prevent stripping screws. Do not overtighten.
5. Turn the assembly right-side up and tighten all sixteen nuts (EE) on leg/rail assembly.

Router Hole Patterns

Figure 7

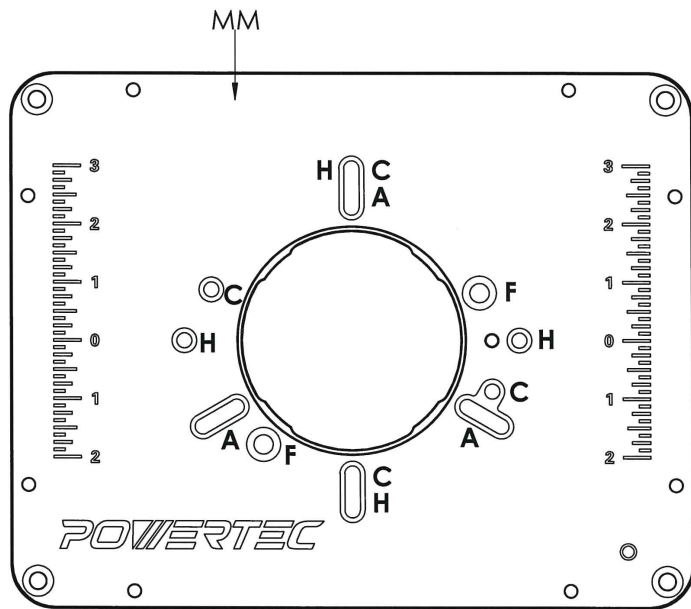

- On the chart find the model and the corresponding letter for your router.
 - Find the corresponding letters for your router in Figure 7. **NOTE:** Some routers have more than one option.
 - Place the insert onto the router and line up the first letter with the appropriate hole and then rotate the plate until all holes for the pattern line up. Install and tighten the machine screws.

PORTER CABLE*	A	690 Series	A	8529 / 7529
	H	7518 / 7519 / 7538 / 7539		
DeWALT*	F	DW621	A	DW616 Series
	F	DW625	A	DW618 Series
Craftsman*	C	315 275 000	A	315 175 060
	A	315 175 040	A	315 175 070
	A	315 175 050		
Bosch*	A	1617 (fixed base)	A	1618
	A	1617 (plunge base)	A	MR23 Series
Makita*	A	RF1101		
Ryobi*	C	R1631K		
Milwaukee*	A	5615	A	5616
	H	5625-20		
Fein*	F	FT 1800		
Elu*	F	177		
Hitachi*	A	M-12VC		
Triton*	H	TRA001	H	MOF001

* PORTER-CABLE, DeWALT, Craftsman and Elu are trademarks of The Stanley Black & Decker Corporation—Bosch is a trademark of the Robert Bosch Tool Corporation—Makita is a trademark of Makita Corporation—Ryobi is a trademark of Ryobi Limited and is used by Techtronic Industries Company LTD—Milwaukee is a trademark of Techtronic Industries Company LTD—Fein is manufactured by C. & E. Fein GmbH—Hitachi is a trademark of Hitachi, Ltd.

IMPORTANT: Store the router sub-base in a convenient place. It will be needed when removing router from the router table and for handheld routing.

- Using the screws that attached the sub-base to the router, attach the router base to the insert plate (MM).

NOTE: Depending on the thickness of your router sub-base, it may be necessary to purchase longer screws. Make certain that the screws are long enough to fully thread into the router base. If you are mounting a fixed-base router, install the motor unit in the router base.

Figure 8

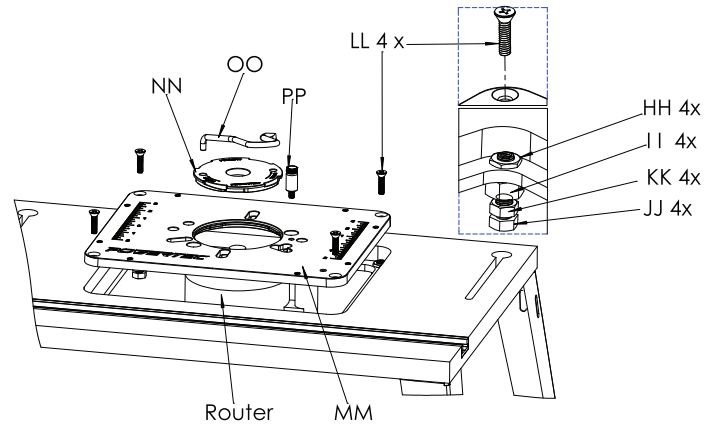

- Place Insert Plate (MM), with the router attached, into the table opening, resting it on Adjustment Screws (JJ). Reaching under the table, turn Adjustment Screws (JJ) until the insert is flush with the table. Use a straight edge to verify the insert plate is flush with the tabletop. Once flush, tighten Nuts (KK) against Hexagon Set Screws (HH). If not flush, fine-tune Adjustment Screws (JJ) until Insert Plate is flush with the tabletop. Tighten each assembly.

NOTE: An additional set of Leveling Screws (RR) is included to fine tune the leveling of Insert Plate (MM) if needed. Insert the 8 Leveling Screws (RR) into the holes (two on each side). Use the 3mm Hex Wrench (SS) to adjust the Leveling Screws (RR) until the Insert Plate is properly level with the tabletop.

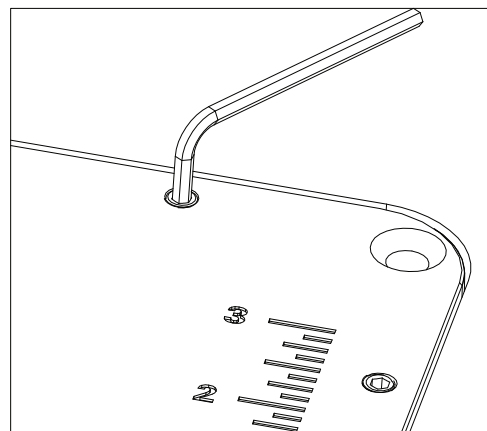

- Thread the four Flat head Screws (LL) through the countersunk holes in the insert plate and into the center hole on each adjustment screws and tighten, locking the insert plate in place. Some adjustment of the lock down screws and adjustment screws may be necessary to fine-tune the alignment.
- Choose the Reducing Ring (NN) appropriate for the job. Using Ring Wrench (OO), in a counterclockwise motion, secure to Aluminum Insert (MM). When needed, thread the starting pin (PP) into the threaded hole in the insert plate and tighten.



Refer to Figure 9–11

- Remove the adhesive backing from the right to left tape measure and press into place. Start on the right end and carefully place the tape along the front edge of the fence. Use scissors to cut the excess tape from the left end.
- Attach the dust port to the back of the fence using the pan head screws and 1/4" washers.
- From the front of the MDF adjustable fence faces, insert the 1/4"-20 x 1-1/2" screws through the MDF adjustable fence face and fence, secure in place with the locking knobs. The MDF adjustable fence faces can be adjusted left or right, after adjustment has been made for the operation to be performed, tighten all knobs securely.
- From the bottom of the fence insert the two 5/16"-18 x 1-1/2" T-Bolts through the fence slot. Place a 5/16" washer and fence locking knob on each T-Bolt. Place the fence onto the router table and align the T-Bolts in the fence with the slots in the router table. Tighten the knobs after adjusting the fence to the operation being performed.
- From the back of the bit guard insert two 1/4"-20 x 1" T-Bolts, place 1/4" washers and locking knobs onto each T-Bolt. Place the T-Bolts into the T-Slot on the face of the fence and slide the bit guard onto the fence. **NOTE:** To adjust the bit guard, loosen the knobs, slide the bit guard up and down to desired application and tighten knobs. When changing bits, slide the bit guard left or right of the opening.

⚠ WARNING

To prevent kickback make sure the featherboard is at least 1" (2.5 cm) from the cutter.

- Place a spacer on each 5/16"-18 x 1-1/2" long T-Bolt and insert through the slot in the featherboard, thread a locking knob on each T-Bolt and slide the T-Bolts into the T-slot in the front of the fence. Position the featherboard and tighten locking knobs.
- Slide the T-Bolt on the flip stop into the T-Slot in top of the fence, tighten the knob. The arm on the flip stop functions as an easily adjustable stop and can be flipped up when not needed. **NOTE:** The flip stop is multi-functional, please see flip stop instructions for details. To prevent chip build up, the stop does not extend the full width of the fence. However when using a stop with material 3/8" thick or less, a longer stop will need to be fabricated and can be mounted in the T-slot located in the front of the fence.

IMPORTANT: Every routing operation is different, adjust the various parts of the router fence and accessories as needed and then tighten all knobs securely.

To Convert from Inboard to Outboard Position

Remove the knob and T-bolt and rotate the stop body 180°. Replace the knob and T-bolt. See below

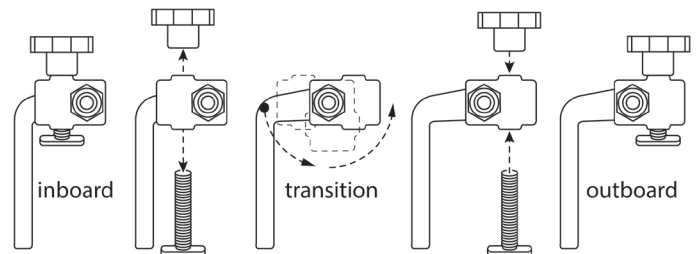

Figure 9

BACK

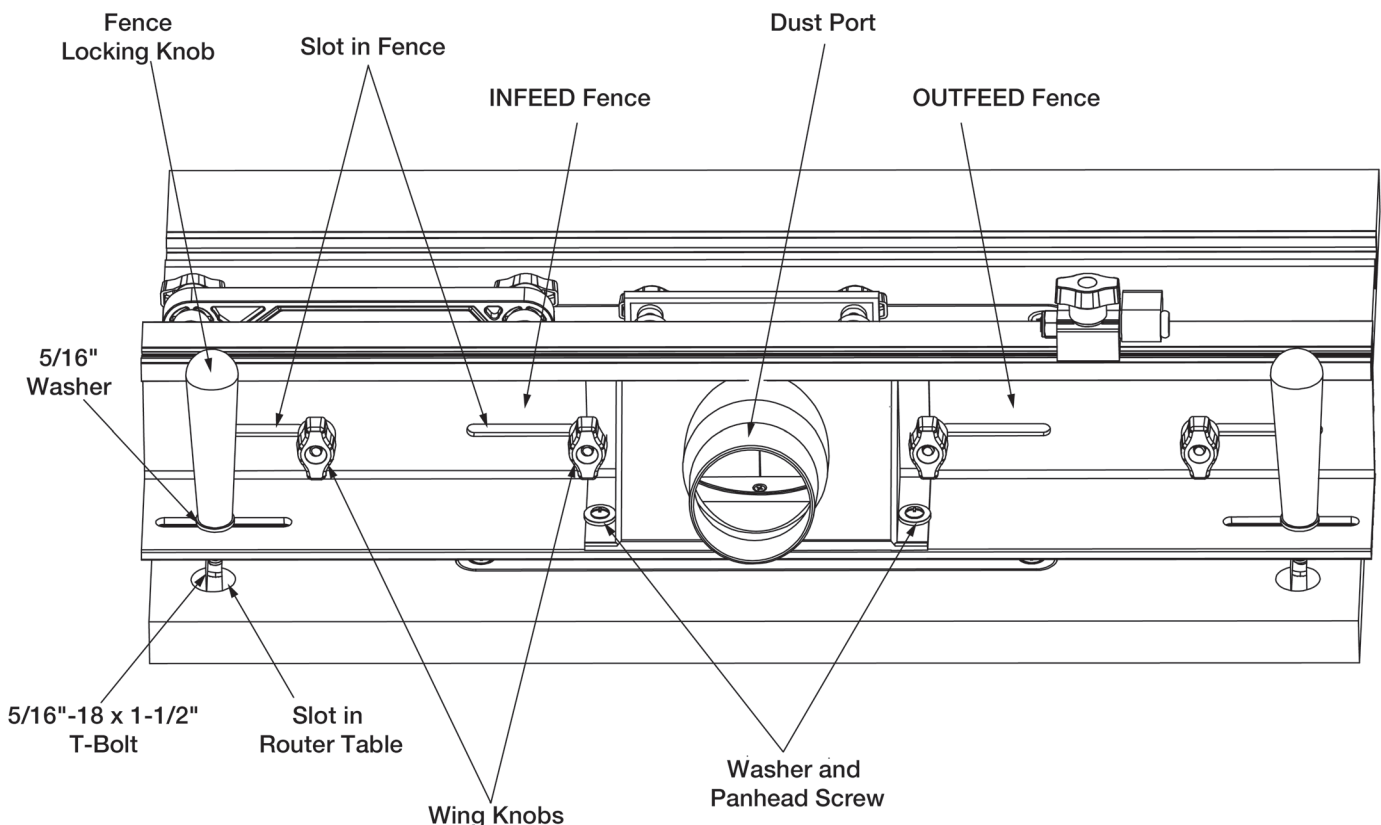
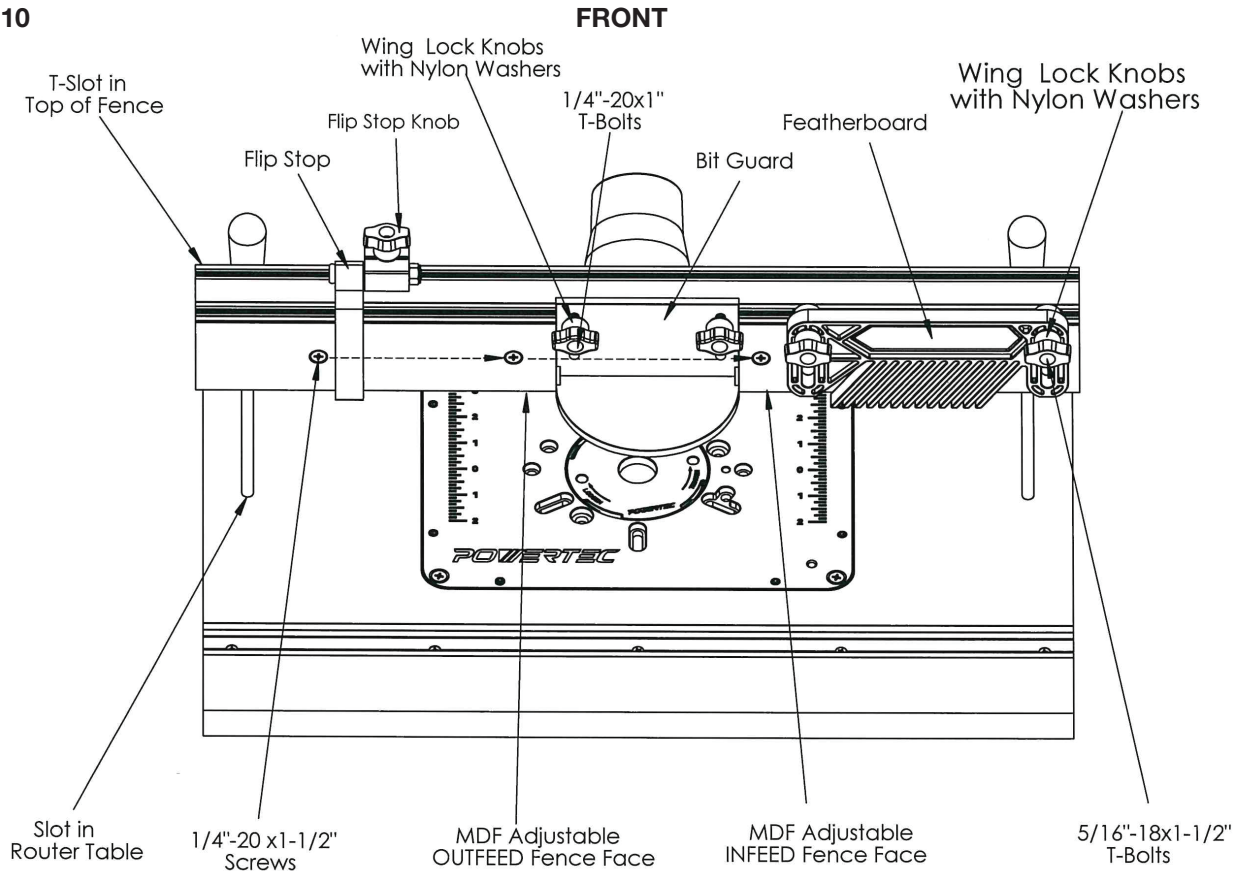

Figure 10



ADJUSTING THE FENCE FACES

Refer to Figure 12

The two MDF adjustable fence faces are designed to slide about 2" along the fence. This allows the opening for the router bit to be adjusted from 0" up to 4".

Generally, the infeed and outfeed adjustable fence faces should be adjusted as close to the bit as possible without contacting the cutter. This will help prevent the ends of the workpiece from drifting too far into the cutter at the beginning and end of the cut to provide quality and safe cut.

Sometimes the "zero-clearance" support is needed to deliver an even cleaner cut. In this case the router bit profile cuts into the front edge of the infeed adjustable fence face so there is virtually no gap between the cutter and the fence face. It delivers a cleaner cut because the workpiece fibers are fully supported throughout the cut.

If a zero clearance setting is necessary, follow these steps:

1. Set the bit height and fence position. Set both of the MDF adjustable fence faces close to the bit without touching it, the fence faces **MUST NOT** contact the bit at this time.

CAUTION

Set the bit guard directly over the router bit, at least 1/2" above the top of the bit or the top of the workpiece (whichever is highest), make sure the bit doesn't cut into the bit guard.

2. Install, adjust and secure the bit guard.
3. On the back of the fence, slightly loosen locking knobs on infeed MDF adjustable fence face. Start the router and slowly slide infeed MDF adjustable fence face into the spinning router bit, stopping when the edge reaches the bit's guide bearing or midpoint (for bits that don't have a guide bearing).

Figure 11

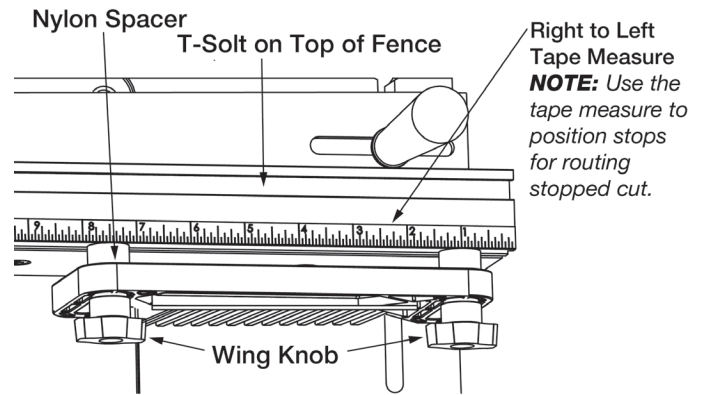

4. Tighten the locking knobs on the back of the MDF adjustable fence face to secure it in position.

Figure 12

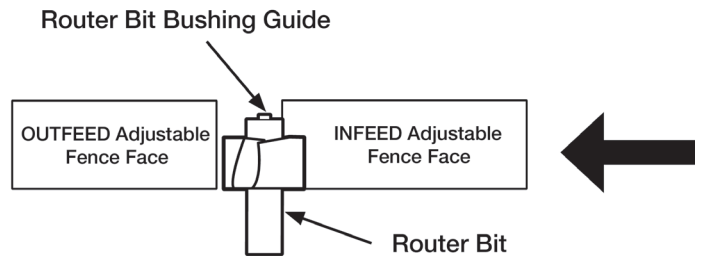



ROUTING

1. Use the insert-plate reducing ring with the smallest opening that allows the bit to pass through it. Position the fence faces as close as possible to the bit. Turn the bit by hand to check for interference.
2. Firmly tighten the fence-face Wing Knobs before routing. Position the bit guard over the router bit and as close to the workpiece surface as possible.
3. Feed the workpiece against (not with) the bit rotation.

REDUCING RINGS

Figure 13

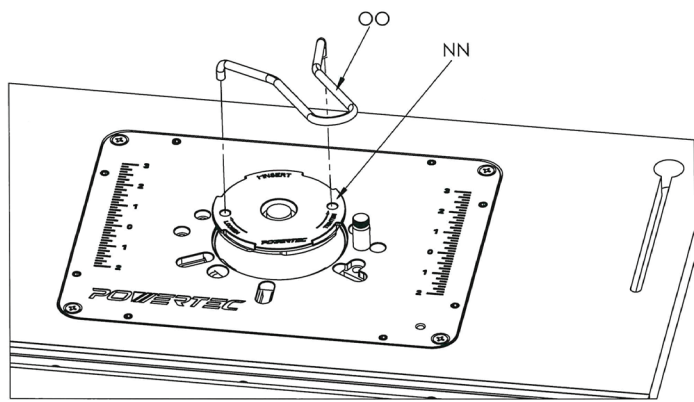

There are four reducing rings for flexibility in matching the size of the insert opening to the diameter of the router bit in use; a solid insert, to be bored for any custom size, an insert with a 1" opening, an insert with a 1 7/8" opening and an insert with a 2-5/8" opening. To install a reducing ring, simply drop it into the insert-plate opening and attach using the Ring Wrench (OO) counterclockwise.

STARTING PIN

To use the starting pin, begin with your workpiece touching the pin, but not in contact with the router bit. Slowly pivot the workpiece into the bit until the workpiece makes contact with the bit guide bearing. Always feed the workpiece so the router bit rotates against (not with) the feed direction. With the workpiece in solid contact with the guide bearing, ease the workpiece off of the starting pin and feed the workpiece against the guide bearing.

WARNING

Use the starting pin when routing along curved edges and only with router bits that have a guide bearing. When routing along straight edges, always use the fence.

JOINTING

Refer to Figure 14–17

The independently adjustable fence faces allow the router table to be used as a vertical jointer by offsetting the outfeed fence face 5/64", 1/16", 3/128" from the infeed fence face.

Two sets of grooves are located in the fence behind the fence faces, slide the jointing rods into these grooves to offset the outfeed fence face 5/64", 1/16", 3/128" from the infeed fence face.

NOTE: It is best to make light passes when jointing, the 3/128" and 1/16" offset will be used more frequently than the 5/64" offset.

1. Loosen the locking knobs securing the outfeed fence face. Slide the jointing rods into the desired groove on the fence.
 - a. For a 5/64" offset—Slide square jointing rods into the square grooves on the outfeed fence. **Figure 14.**
 - b. For a 1/16" offset—Slide round jointing rods into the round grooves on the outfeed fence. **Figure 15.**
 - c. For a 3/128" offset—This is the only setup using both sets of jointing rods. Slide square jointing rods into the square grooves on the OUTFEED fence. Slide round jointing rods into the round grooves on the INFEED fence. **Figure 16.**

Figure 14

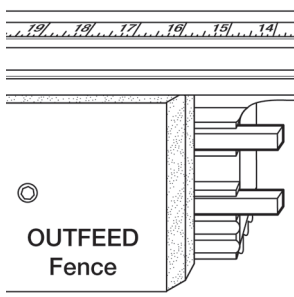

Square jointing rods shown in the square grooves for the 5/64" offset.

Figure 15

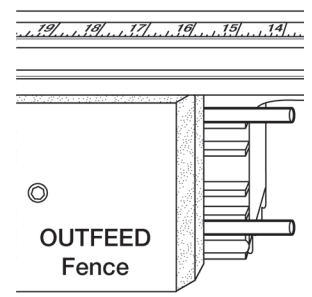

Round jointing rods shown in the round grooves for the 1/16" offset.

Figure 16

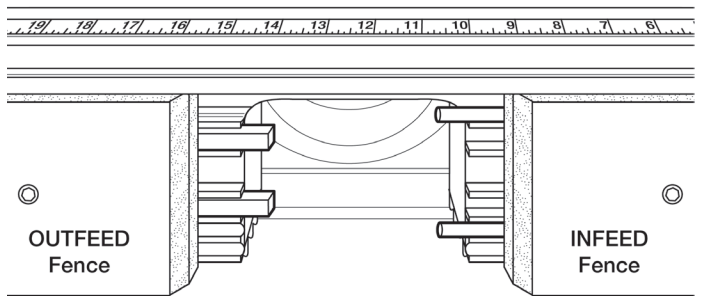

Square jointing rods shown in the square grooves on the OUTFEED fence. Round jointing rods in the round grooves on the INFEED fence for the 3/128" offset.

2. With the rods in place, tighten the fence face locking knobs.

Figure 17-a

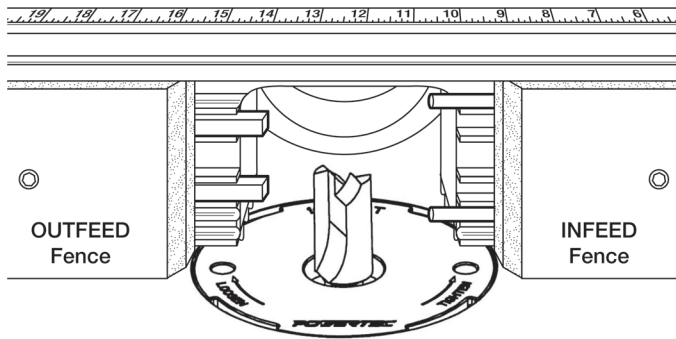

3. Install a straight bit in the router. Place a straight edge against the outfeed fence face and position the fence so the bit just grazes the straight edge.

NOTE: Make sure all rods are clear of cutter.

NOTE: Any straight bit can be used for jointing. A flush-trim bit is the easiest to set up because the bit guide bearing is the same diameter as the cutter and it can be aligned to the outfeed fence face with the bearing. An up-cut spiral bit produces an almost chatter-free surface, but it is more difficult to align with the fence face.

Figure 17-b (Top View with workpiece)

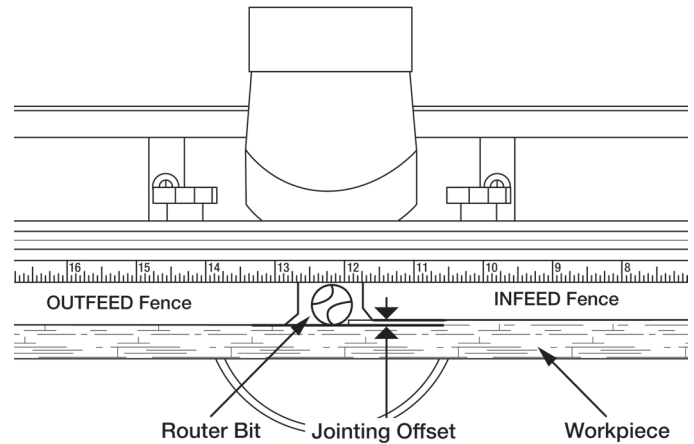

Always use a scrap piece of wood to test the setup.

- If the scrap is fed past the bit and it runs into the leading end of the outfeed fence face, the fence is too far forward and not enough material is being removed. Move the fence back a little.
- If there is snipe at the trailing edge of the scrap, the fence is too far back and too much material is being removed. Move the fence forward.

MAINTENANCE



10

GENERAL MAINTENANCE

WARNING

When servicing, use only identical replacement parts. Use of any other parts may create a hazard or cause product damage. To ensure safety and reliability, all repairs should be performed by a qualified service technician.

WARNING

Keep the bench top router table dry, clean, and free from oil and grease. Always use a clean cloth when cleaning. Never use brake fluids, gasoline, petroleum based products or any strong solvent to clean the bench top router table. Chemicals can damage, weaken or destroy plastic which may result in serious personal injury.

Thank you for investing in a **POWERTEC** power tool. This product has been designed and manufactured to meet high quality standards and is guaranteed for domestic use against defects in workmanship or material for a period of 12 months from the date of purchase. This guarantee does not affect your statutory rights.

SOUTHERN TECHNOLOGIES LLC. BENCH TOP AND STATIONARY POWER TOOL LIMITED 1 YEAR WARRANTY AND 30-DAY SATISFACTION GUARANTEE POLICY

POWERTEC products are designed and manufactured by **Southern Technologies LLC**. All warranty communications should be directed to **Southern Technologies LLC** by calling 847-780-6120 (toll free), 9 AM to 5 PM, Monday through Friday, US Pacific Time.

30-DAY SATISFACTION GUARANTEE POLICY

During the first 30 days after the date of purchase, if you are dissatisfied with the performance of this **POWERTEC** tool for any reason, you may return the tool to the retailer from which it was purchased for a full refund or exchange. You must present proof of purchase and return all original equipment packaged with the original product. The replacement tool will be covered by the limited warranty for the balance of the one year warranty period.

LIMITED ONE YEAR WARRANTY

This warranty covers all defects in workmanship or materials in this **POWERTEC** tool for a one year period from the date of purchase. This warranty is specific to this tool. **Southern Technologies, LLC** reserves the right to repair or replace the defective tool, at its discretion.

HOW TO OBTAIN SERVICE

To obtain service for this **POWERTEC** tool you must return it, freight prepaid, to **POWERTEC**. You may call (toll free) 847-780-6120 for more information. When requesting warranty service, you must present the proof of purchase documentation, which includes a date of purchase. **POWERTEC** will either repair or replace any defective part, at our option at no charge to you. The repaired or replacement unit will be covered by the same limited warranty for the balance of one year warranty period.

WHAT IS NOT COVERED

This warranty applies to the original purchaser at retailer and may not be transferred.

This warranty does not cover consumable items such as saw blades, knives, belts, discs, cooling blocks and sleeves. This warranty does not cover required service and part replacement resulting from normal wear and tear, including accessory wear.

This warranty does not cover any malfunction, failure or defect resulting from:

- 1) misuse, abuse, neglect and mishandling not in accordance with the owner's manual.
- 2) damage due to accidents, natural disasters, power outage, or power overload.
- 3) commercial or rental use.
- 4) alteration, modification or repair performed by persons not recommended by **POWERTEC**.

DISCLAIMER

To the extent permitted by applicable law, all implied warranties, including warranties of MERCHANTABILITY or FITNESS FOR A PARTICULAR PURPOSE, are disclaimed. Any implied warranties, that cannot be disclaimed under state law are limited to one year from the date of purchase. **Southern Technologies LLC**. is not responsible for direct, indirect, incidental or consequential damages. Some states do not allow limitations on how long an implied warranty lasts and/or do not allow the exclusion or limitation of incidental or consequential damages, so the above limitations may not apply to you. This warranty gives you specific legal rights, and you may also have other rights which vary from state to state. Southern Technologies LLC., makes no warranties, representations, or promises as to the quality or performance of its power tools other than those specifically stated in this warranty.

POWERTEC®

Southern Technologies, LLC
Chicago, IL 60606